



Product Catalog

## CLCA Series

# Flexible Air Handling Unit

CLCA 003~100

2000~120000CMH

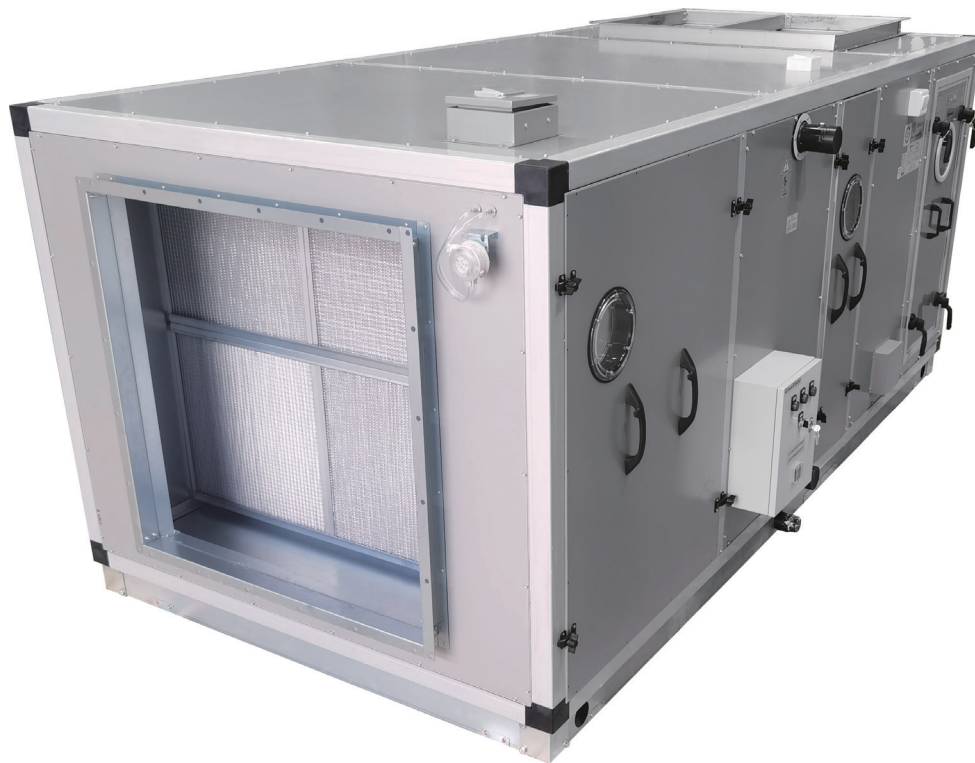



# Introduction

Trane has been manufacturing air handling units throughout the world for the past 40 years. This proven worldwide experience enables us to develop a world class air handling unit, the new Climate Changer Advanced. Climate Changer Advanced is a combination of 4 key elements:

## 1. Globally Integrated Research and Development

A global marketing team comprising air handling specialist from Europe, Asia Pacific and China, Middle East, Africa and South America was formed to provide critical customer and market needs. A global design team comprising design specialist from the Trane Technology Center, USA, Trane Europe and the Trane Air Handling International Development Center in Asia was formed to develop new world class air handling technology.

## 2. World Class Manufacturing Facility

The Climate Changer Advanced manufacturing facility is certified to MS ISO 9001 and is one of the earliest American facilities certified to Demand Flow Technologies (DFT). DFT is a technology that takes quality to the people and the machines that produce the product. In addition, Total Quality Control methodology within DFT brings quality into the manufacturing process at the point where work is being performed, resulting in consistent product quality.

## 3. Performance Assurance and Commitment to Quality

Trane combines comprehensive performance certifications with thorough laboratory testing and manufacturing methods. Together, these elements assure that each Climate Changer Advanced operates predictably and reliably throughout the life of the unit.

## 4. Matching Technologies to Systems

The building industry is continuously evolving and the rate of change is accelerating. Technologies, economic, regulatory and environmental factors are very different now than there were just a few years ago, which will affect the application and installation of the HVAC systems. Recognizing this and utilizing the Trane worldwide air conditioning system experience, the Climate Changer Advanced was developed and packaged to suit most current air conditioning system application needs.

### Purpose

The purpose of this catalogue is to help consulting engineers in the preliminary selection of the Climate Changer Advanced air handling units. Your regional Trane office will assist to provide a computerized selection to confirm or complete your preliminary selection. Where something more special is required, we have full technical support in our regional sales offices and at our factory where non-standard layouts and configurations can be designed to individual requirements.

## Features and Benefits

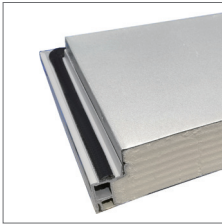

### Ultra Low Leak Construction

Unique casing design with step panel attached to the frame supported by uninterrupted integrated sealing material, exerting pressure evenly onto the panel and the seal attached to the frame, and hence a better air tight cabinet construction. The casing is designed to meet Eurovent Casing Air Leakage Standard.

### Excellent Condensate Management

Dual pitched sloping drain pan allows for total condensate removal. A unique feature developed to prevent stagnant water in air handling units.



### Environmental Friendly Materials

High-grade aluminium frame is non-corrosive and is easily clean-able. All these features will further enhance indoor air quality.

### Design for Routine Cleaning

Double wall panel construction allows for easy cleaning and disinfecting of the interior surfaces. The panel-type hinged door with the same height as the panel makes it easier to enter the interior of the box.

Panel and frame design allows for easy removal of side panels for maximum access to internal areas.

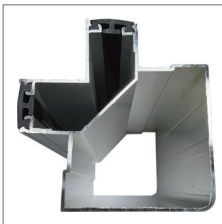

### High Grade Aluminum Frame

Frame is constructed of extruded aluminum channels for structural rigidity and lightness.

### Injected Polyurethane Foam Panels

All panels are injected with high efficiency polyurethane foam insulation. Foamed panels provide superior thermal resistance properties, and have excellent acoustic and vibration absorption characteristics. In addition, polyurethane foam does not absorb moisture and will not promote fungus growth.



### High Efficiency Performance

Patented heat transfer technology gives maximum cooling and dehumidification. Trane engineered fan systems provide maximum airflow while minimizing vibration, acoustic levels and power consumption.

### Suitable for Retrofit, Renovation and Replacement

Change is inevitable. As time passes, building loads alter, new technologies emerge and codes and standards are revised. The Climate Changer Advanced design lends itself to the needs of the renovation, retrofit and replacement market.

### Sturdy Unit Construction

The Climate Changer Advanced's flexibility is contributed by the structural integrity pentapost and panel construction. That not only means you can stack modules in a space-saving vertical air-handler configuration, but also allows removal of panels for unlimited access. The casing strength is designed to meet European Standard EN 1886:2007.



## Features and Benefits

---



### Optimized Coils

Flexibility characterizes the Climate Changer Advanced's broad coil offering. The variety of types, sizes, arrangements and materials enables you to select a coil optimized for the application pressure drop and capacity requirements. Options include:

- 2 to 12 rows, 1/2 inch OD chilled water coils and two separate cooling coil in series to meet high capacity requirement.
- One and two rows, 1/2 inch OD hot water coils.
- Four and six rows, 1/2 inch OD refrigerant coils.
- One row 1/2 inch OD, distributing type steam coils.
- Infinitely variable fin spacing (IVS).
- Stainless steel coil casing (option). Copper fins.
- Coated aluminum fin for corrosion resistance.
- Header drain and vent connections.
- Fully drain able coils at header.

All standard heating and cooling coils are engineered and manufactured at Trane air handling systems manufacturing facility.

### Performance Assurance and Commitment to Quality

Trane combines comprehensive performance certifications with thorough laboratory testing and manufacturing methods. Together these elements help to ensure that each Climate Changer Advanced operates predictably and reliably throughout the life of the unit. All fans are tested as per ANSI/AMCA 210, ANSI/ASHRAE Standard 51 - Laboratory Method of Testing Fans for Rating and AMCA 300 "Reverberant Room Method for Sound Testing of Fans."

All coil capacities, pressure drops and selection procedures are rated in accordance to ARI Standard 410. All coils are leak and proof tested to min 375 psig.

Climate Changer Advanced is manufactured in a facility that is certified to MS ISO9001.

# Quick Selection

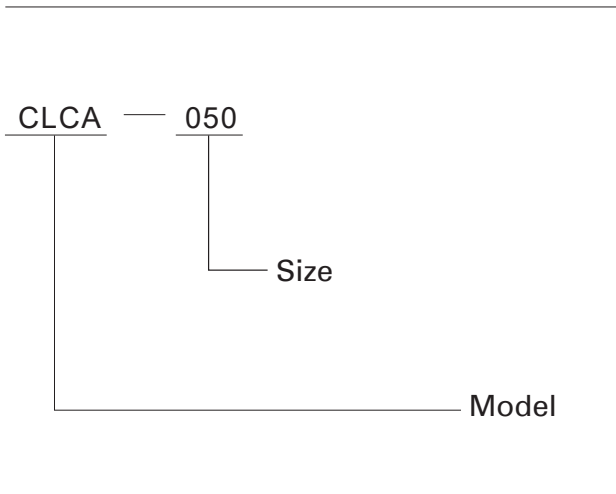

### Definition of Unit Direction

Staying opposite to air flow direction, the unit is defined as Left if coil connection & service door is located on the left; vice versa.

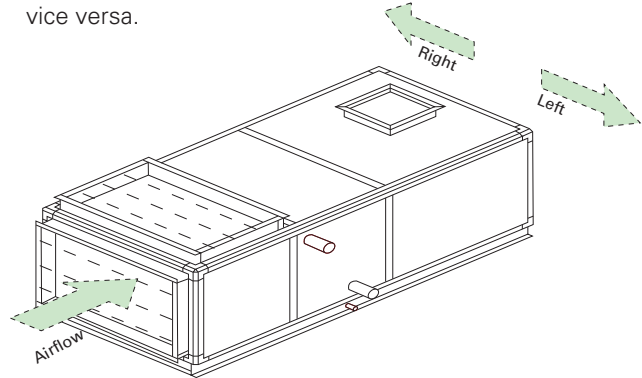

Model Size	Nominal Airflow m <sup>3</sup> /h	Coil Face Area m <sup>2</sup>	Nominal Airflow m <sup>3</sup> /h					Width		Height	
			2.0m/s	2.25m/s	2.5m/s	2.75m/s	3.0m/s	25mm	50mm	25mm	50mm
003	2300	0.23	1656	1863	2070	2277	2484	689	739	789	839
004	4000	0.40	2880	3240	3600	3960	4320	999	1049	789	839
006	5500	0.56	4032	4536	5040	5544	6048	1309	1359	789	839
008	7000	0.73	5256	5913	6570	7227	7884	1619	1669	789	839
010	9000	0.89	6408	7209	8010	8811	9612	1309	1359	1099	1149
012	11000	1.15	8280	9315	10350	11385	12420	1619	1669	1099	1149
014	14000	1.42	10224	11502	12780	14058	15336	1929	1979	1099	1149
016	16000	1.58	11376	12798	14220	15642	17064	1619	1669	1409	1459
020	19000	1.94	13968	15714	17460	19206	20952	1929	1979	1409	1459
025	23000	2.30	16560	18630	20700	22770	24840	1929	1979	1719	1769
030	29000	2.86	20592	23166	25470	28314	30888	1929	1979	2029	2079
035	34000	3.42	24624	27702	30780	33858	36936	2239	2289	2029	2079
040	40000	3.95	28440	31995	35550	39105	42660	2549	2599	2029	2079
045	45000	4.48	32256	36288	40320	44352	48384	2859	2909	2029	2079
050	50000	5.01	36072	40581	45090	49599	54108	3169	3219	2029	2079
060	60000	5.92	42624	47952	53280	58608	63936	-	3219	-	2389
065	65000	6.55	47160	53055	58950	64845	70740	-	3529	-	2389
070	70000	7.18	51969	58158	64620	71082	77544	-	3839	-	2389
080	80000	7.81	56232	63261	70290	77319	84348	-	4149	-	2389
085	85000	8.44	60768	68364	75960	83556	91152	-	4459	-	2389
090	90000	9.07	65304	73467	81630	89793	97956	-	4769	-	2389
095	100000	9.70	69840	78570	87300	96030	104760	-	5079	-	2389
100	105000	11.2	80640	90720	100800	110988	120000	-	5079	-	2699

Note: Standard unit base height 100mm. Special design requirement, please contact technical department.

## Quick Selection

Item	Section	Unit model / Specs	Length (mm)	General Options
1	Mixing box/intake section	003-020	310	Manual damper Electric-driven damper Access door Inspection lamp
		025-035	465	
		040-050	620	
		060-080	775	
		085-100	930	
2	Per-filter section	003-100	155	2" flat washable per-filter Bag filter (variable specs) Pressure differential gauge
3	Secondary filter section	003-100	465	
4	Flat + Bag Filter section	003-100	620	
5	Cooling Coil section	003-100 / 2 Row	310	2-12 row cooling coil, Al /copper fin, Drop eliminator Film humidifier Steel / copper header Coil turbulator
		003-100 / 4 Row	465	
		003-100 / 4 Row	465	
		003-100 / 6 Row	465	
		003-100 / 8-12 Row	620	
6	Hot water coil section	003-100 / 1 Row	310	1-4 row heating coil, Al/ copper fin, Steel / copper header Coil turbulator
		003-100 / 2 Row	310	
		003-100 / 4 Row	465	
7	Steam coil section	003-100	310	2 Row steam coil
8	Electric heater section	003-100	465	Electric heater power, heater stage
9	Steam humidifier section	003-100	775	Manual operation, On/off control modulating control
10	Film humidifier section	003-100	155	Efficiency: 40% or 60% (Mounted behind coil)
			310	Efficiency: 80% or 90% (Mounted behind coil) Efficiency: 40% or 60% (Mounted separately)
			465	Efficiency: 80% or 90% (Mounted separately)
11	High-pressure atomizing humidifier section (include drop eliminator)	003-100	1240	
12	Fan section	003-100	775-2790	FC/BC/AF/Plug Fan
13	Sound Attenuator section	003-100	465-1240	Section length per custom requirements
14	Hi-capacity filter section	003-100	620	Pressure differential gauge
15	Access section	003-100	465/620	Latched door Hinged door Pressure differential gauge
16	Supply airflow section	003-020	310	Manual damper Electric-driven damper Access door Inspection lamp
		025-035	465	
		040-050	620	
		060-080	775	
		085-100	930	
17	Heat wheel section	003-100	620	High or standard efficiency

Note: All heat recovery systems, plenum fan, sound attenuator and non TRANE coil are non EUROVENT certified.

# Cooling Coil Performance Table

## Mixed air condition

Model Size	Nominal Airflow m <sup>3</sup> /h	4 Rows					6 Rows			
		Total Cap. kW	Sensible Cap. kW	APD Pa	WFR L/S	WPD kPa	Coil type	Total Cap. kW	Sensible Cap. kW	APD Pa
003-1010	2300	5.9	5.9	90.2	0.28	0.3	WL	8.4	8.2	152
004-1510	4000	12.3	12.0	102.7	0.6	1.4	WL	21.9	17.3	181.4
006-2010	5500	23.4	20.3	112.8	1.14	5.1	WL	34.7	25.6	180.9
008-2510	7000	33.8	27.4	114.8	1.64	11.2	WL	46.9	33.8	179.7
010-2015	9000	38.5	33.2	118	1.87	5.1	WL	56.8	41.9	189
012-2515	11000	54.1	43.4	113.1	2.63	10.7	WL	74.8	53.5	177
014-3015	14000	71.9	56.3	121.7	3.5	19.9	WL	97.3	68.9	188.5
016-2520	16000	77.3	62.4	123.4	3.76	11.3	WL	107.2	77.1	193
020-3020	19000	98.6	76.9	120	4.8	19.5	WL	133.1	94.0	185.9
025-3025	23000	121.1	93.9	115.5	5.89	19.7	WL	162.8	114.6	178.9
030-3030	29000	149.2	116.7	121.4	7.26	20	WL	201.7	142.8	188.2
035-3530	34000	182.3	139.8	121	8.87	31.5	WL	242.8	170.1	186.6
040-4030	40000	218.7	166.1	125.2	10.64	47.4	WL	259.6	189.3	186.7
045-4530	45000	252.1	189.4	124.5	12.26	65.9	WL	300.8	216.7	185.7
050-5030	50000	249.0	198.2	118.6	12.11	15.7	LL	341.7	243.9	184.9
060-5035	60000	295.8	236.2	124.5	14.39	18.7	LL	406.6	291.0	194
065-5535	65000	332.4	260.9	121.9	16.17	24.1	LL	450.7	319.6	189.1
070-6035	70000	368.5	285.4	119.6	17.92	30.2	LL	494.6	348.2	185
080-6535	80000	420.0	324.8	129.2	20.43	39.9	LL	562.6	396.4	199.3
085-7035	85000	456.3	349.4	126.7	22.2	48.1	LL	606.8	425.1	195.1
090-7535	90000	492.5	374.0	124.6	23.96	57.2	LL	609.2	431.7	190.6
095-8035	100000	544.9	413.7	132	26.51	71.1	LL	651.8	468.9	199.3
100-8040	105000	596.0	446.2	115.3	28.99	72.5	LL	697.0	498.5	170.1

Model Size	Nominal Airflow m <sup>3</sup> /h	6 Rows					8 Rows			
		WFR L/S	WPD kPa	Coil type	Total Cap. kW	Sensible Cap. kW	APD Pa	WFR L/S	WPD kPa	Coil type
003-1010	2300	0.41	0.7	WL	12.3	10.0	227.3	0.6	1.7	WL
004-1510	4000	1.06	4.9	WL	28.0	20.0	251.7	1.36	9	WL
006-2010	5500	1.69	13.1	WL	41.9	28.9	246.7	2.04	22.2	WL
008-2510	7000	2.28	25.8	WL	55.6	37.8	243.6	2.71	42.4	WL
010-2015	9000	2.76	13.2	WL	68.7	47.4	257.7	3.34	22.3	WL
012-2515	11000	3.64	24.6	WL	88.4	59.8	239.9	4.3	40.3	WL
014-3015	14000	4.73	44.3	WL	114.0	76.8	254.8	5.55	71.9	WL
016-2520	16000	5.22	26.1	WL	127.1	86.4	261.6	6.18	43	WL
020-3020	19000	6.47	43.2	WL	155.7	104.7	251.3	7.57	69.9	WL
025-3025	23000	7.92	43.2	WL	170.7	119.1	234.8	8.3	17.9	LL
030-3030	29000	9.81	44.5	WL	212.4	148.9	247.2	10.33	13	LL
035-3530	34000	11.81	68.6	WL	259.4	179.0	245.9	12.62	20.2	LL
040-4030	40000	12.63	21.1	LL	311.2	213.1	253.9	15.14	30.2	LL
045-4530	45000	14.63	29.5	LL	357.1	242.8	251.9	17.37	41.4	LL
050-5030	50000	16.62	39.5	LL	402.9	272.4	250.3	19.6	54.7	LL
060-5035	60000	19.78	45.8	LL	480.3	325.4	262.7	23.36	63.6	LL
065-5535	65000	21.92	58.2	LL	528.9	356.4	255.6	25.73	79.8	LL
070-6035	70000	24.06	72.5	LL	577.3	387.2	249.8	28.08	98.2	LL
080-6535	80000	27.37	96.1	LL	621.4	421.6	269.3	25.8	89.5	LL
085-7035	85000	29.52	115.3	LL	653.1	445.0	261.1	25.2	89.3	LL
090-7535	90000	24.9	89.7	LL	683.0	467.6	253.8	24.6	89	LL
095-8035	100000	24.4	89.8	LL	732.2	508.0	265.4	24.2	89.7	LL
100-8040	105000	24.87	98.3	LL	754.0	527.6	224.4	23.54	68.8	LL

Note: 1. Enter Dry Bulb temperature 27°C, Enter Wet Bulb temperature 19.5°C, chilled Enter/Leaving Water Temperature 7°C/12°C.  
 2. The coil is copper turb Al. fin, 10 Fins per inch.  
 3. If airflow of FPI increase, the total cap. Increase also.  
 4. Underlined data is generated at larger water temperature rise (than 5°C) to leverage water pressure drop.

## Cooling Coil Performance Table

### Fresh air condition

Model Size	Nominal Airflow m <sup>3</sup> /h	4 Rows						6 Rows		
		Total Cap. kW	Sensible Cap. kW	APD Pa	WFR L/S	WPD kPa	Coil type	Total Cap. kW	Sensible Cap. kW	APD Pa
003-1010	2300	16.7	9.0	130.7	0.81	2.1	WL	28.4	13.0	196.0
004-1510	4000	41.1	19.3	134.5	2.0	13.0	WL	57.1	25.3	201.7
006-2010	5500	62.9	28.7	129.2	3.06	32.2	WL	83.6	36.7	193.8
008-2510	7000	84.6	38.1	126.3	4.11	61.5	WL	100.0	44.3	189.5
010-2015	9000	103.0	46.9	134.9	5.01	32.1	WL	136.8	60.0	202.3
012-2515	11000	135.3	60.7	124.4	6.58	58.8	WL	159.3	70.4	186.5
014-3015	14000	153.2	70.7	131.3	7.45	20.3	LL	207.8	91.5	196.9
016-2520	16000	162.8	76.8	135.6	7.92	15.8	LL	228.3	101.1	203.4
020-3020	19000	210.0	96.7	129.4	10.22	26.8	LL	284.2	125.0	194.2
025-3025	23000	258.0	118.5	124.5	12.55	33.0	LL	341.1	149.5	203.4
030-3030	29000	317.7	146.7	131	15.45	20.9	LL	408.0	180.2	207.6
035-3530	34000	390.5	178.0	129.1	18.99	32.4	LL	513.3	224.5	201.8
040-4030	40000	470.1	213.0	132.4	22.86	48.0	LL	595.8	260.9	207.0
045-4530	45000	543.1	244.6	130.8	26.42	65.7	LL	643.9	290.0	204.4

Model Size	Nominal Airflow m <sup>3</sup> /h	6 Rows						8 Rows		
		WFR L/S	WPD kPa	Coil type	Total Cap. kW	Sensible Cap. kW	APD Pa	WFR L/S	WPD kPa	Coil type
003-1010	2300	1.38	6.7	WL	35.4	15.6	261.4	1.7	11.6	WL
004-1510	4000	2.78	28.8	WL	67.3	29.3	268.9	3.27	45.4	WL
006-2010	5500	4.06	66.7	WL	88.8	38.8	258.4	4.32	15.0	LL
008-2510	7000	4.86	20.1	LL	118.1	51.4	252.6	5.74	28.3	LL
010-2015	9000	6.66	66.7	LL	145.5	63.6	269.8	7.08	20.9	LL
012-2515	11000	7.75	26.2	LL	187.5	81.5	248.7	9.1	36.5	LL
014-3015	14000	10.11	46.4	LL	242.1	105.2	262.5	11.78	63.5	LL
016-2520	16000	11.11	36.0	LL	269.7	117.4	271.2	13.12	51	LL
020-3020	19000	13.82	57.9	LL	319.0	138.3	262.9	14.22	62.8	LL
025-3025	23000	15.70	78.6	LL	384.7	166.9	271.2	15.70	80.2	LL
030-3030	29000	15.70	63.0	LL	463.0	201.6	276.8	15.70	64	LL
035-3530	34000	25.82	79.4	LL	582.1	252.1	269.1	27.20	89.7	LL
040-4030	40000	26.60	89.5	LL	669.8	290.5	276.0	26.20	89.6	LL
045-4530	45000	25.80	89.7	LL	743.0	322.6	272.6	25.20	89.6	LL

Note: Entering air temperature 35/28°C (Dry/Wet Bulb); entering & leaving water temperature: 7/12°C.



## Fan & Motor Parameter

CLCA	Airflow	Fan Model	Fan Dimension	Motor Power	Internal Pressure Drop	Motor Power	
						@300Pa*	@700Pa*
Model	CMH		mm	kW	Pa	kW	kW
003	2070	KAT 9-7	229	0.55-3	341	1.1	1.5
004	3600	KAT 10-8/BC 225	250/225	0.55-3	363	1.5	3.0
006	5040	FC/BC 250	250	0.55-7.5	370	3.0	4.0**
008	6570	FC/BC 280	280	0.75-7.5	386	3.0	4.0
010	8010	FC/BC 315	315	1.1-7.5	370	4.0	7.5
012	10350	FC/BC 400	400	1.1-15	383	5.5	5.5**
014	12780	FC/BC 400	400	1.5-15	382	5.5	7.5**
016	14220	FC/BC 450	450	1.5-18.5	375	5.5	7.5**
020	17460	FC/BC 500	500	2.2-18.5	378	7.5	11.0**
025	20700	FC/BC 560	560	2.2-22	370	7.5	11.0**
030	25740	FC/BC 560	560	4-30	377	11.0	15.0
035	30780	FC/BC 630	630	4-37	380	15.0	15.0
040	35550	FC/BC 710	710	4-37	381	15.0	22.0**
045	40320	FC/BC 710	710	4-37	382	15.0	22.0**
050	45090	FC/BC 800	800	5.5-45	382	18.5	22.0**
060	53280	FC/BC 800	800	7.5-75	382	22.0	30.0
065	58950	FC/BC 900	900	7.5-75	379	22.0	30.0**
070	64620	FC/BC 900	900	7.5-75	380	30.0	30.0**
080	70290	FC/BC 1000	1000	7.5-75	381	30.0	7.0**
085	75960	FC/BC 1000	1000	7.5-75	381	30.0	7.0**
090	81630	FC/BC 1000	1000	11-75	370	37.0	5.0
095	87300	FC/BC 1000	1000	11-75	382	37.0	45.0**
100	105000	AF/BC 1120	1120	15-75	330	37.0	45.0**

\*Default unit configuration: Mixing + Pre & Bag filter + 6 Row 120FPF Coil + Top Discharge Fan

\*\* BC (Backcurved) fan is used.

## Filter Section

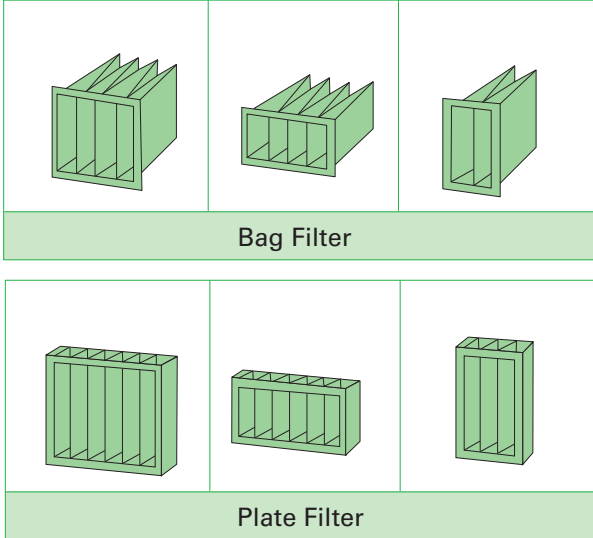

- Plate per-filter efficiency, efficiency  $\geq 20\%$ (G4, @1  $\mu\text{m}$  Chinese classification GB12218-89)
- Bag secondary filter, efficiency  $\geq 65\%$ (F6),  $\geq 85\%$ (F7) or  $\geq 95\%$ (F8) (Dust-spot).
- HEPA High efficiency particulate air filter, efficiency  $\geq 99.97\%$ (H12)(MPPS).

Dimensions & quantity of Plate filter & Bag filter

Model	Back Loading				Side Loading		
	12"x24"	24"x12"	24"x24"	24"x20"	12"x24"	24"x12"	24"x24"
003-0404	2			1			
004-0604	2			1			
006-0804		4		2			
008-1004		4		2			
010-0806		2	2		2	2	
012-1006	1	2	2		1	2	2
014-1206		3	3			3	3
016-1008		2	4		2		4
020-1208			6				6
025-1210		3	6			3	6
030-1212			9				9
035-1412	3		9		3		9
040-1612			12				12
045-1812	3		12		3		12
050-2012			15				15
060-2014		5	15			5	15
065-2214	3	5	15		3	5	15
070-2414		6	18			6	18
080-2614	3	6	18		3	6	18
085-2814		7	21			7	21
090-3014	3	7	21		3	7	21
095-3214		8	24			8	24
100-3216			32				32

## Damper Position & Dimensions

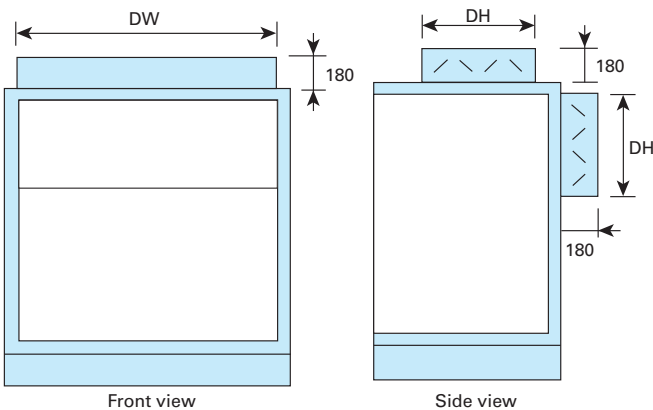

25mm & 50mm Casing

Unit Model	DW(mm)	DH(mm)
003-0404	620	310
004-0604	930	310
006-0804	1240	310
008-1004	1550	310
010-0806	1240	310
012-1006	1550	310
014-1206	1860	310
016-1008	1550	310
020-1208	1860	310
025-1210	1860	465
030-1212	1860	465
035-1412	2170	465
040-1612	2480	620
045-1812	2790	620
050-2012	3100	620
060-2014	3100	775
065-2214	3410	775
070-2414	3720	775
080-2614	4030	775
085-2814	4030	930
090-3014	4030	930
095-3214	4030	930
100-3216	4030	930

Note: The damper sizes are internal sizes.

# Humidifier Section

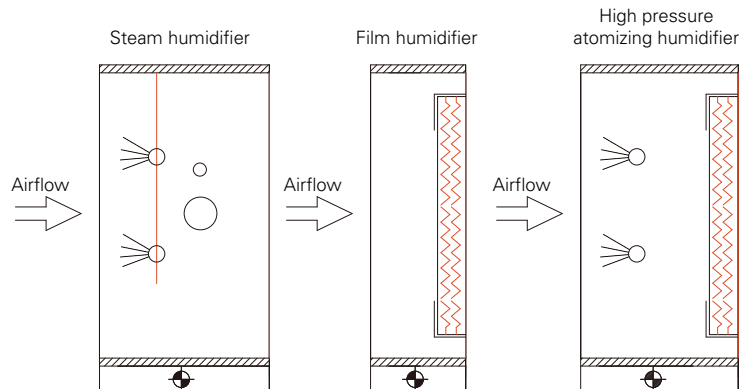

Model Size	Nominal Airflow m <sup>3</sup> /h	Dry steam humidifier kg/h	Wet film humidifier (kg/h)				Recommended High pressure atomizing humidifier (kg/h)
			30%	55%	70%	80%	
003	2300	6.0-20	5.5	10.6	13.4	15.4	5-15
004	4000	8.0-40	9.4	18	23	26.2	5-15
006	5500	20-55	13.1	25.1	31.9	36.5	10-25
008	7000	30-80	17	32.6	41.4	47.4	15-35
010	9000	40-80	20.9	40	51	58.2	25-45
012	11000	60-120	26.9	51.5	65.5	74.9	30-55
014	14000	80-180	32.9	62.9	80.1	91.5	40-70
016	16000	100-200	36.8	70.4	89.6	102.4	50-80
020	19000	120-220	45.1	86.2	109.8	125.4	50-95
025	23000	120-220	55.9	106.9	136.1	155.5	65-120
030	29000	180-300	67.2	128.5	163.5	186.9	75-145
035	34000	280-400	79.4	151.8	193.2	220.8	100-170
040	40000	300-480	91.8	175.6	223.4	255.4	100-200
045	45000	300-480	104.2	199.3	253.7	289.9	130-230
050	50000	300-480	116.6	223.1	283.9	324.5	150-250
060	60000	400-550	137.5	263.1	334.9	382.7	180-300
065	65000	400-550	152	290.8	370.2	423	200-330
070	70000	450-600	166.8	319	406	464	210-350
080	80000	500-700	181.2	346.7	441.3	504.3	240-400
085	85000	550-750	196	374.9	477.1	545.3	260-430
090	90000	600-800	210.5	402.6	512.4	585.6	270-450
095	100000	700-900	224.9	430.3	547.7	625.9	300-500
100	105000	700-900	243.3	465.4	592.3	677.0	300-500

Note: 1. Assumed Condition: entering air dry bulb temperature:4°C and 15% relative humidity; face velocity = 2.5m/s and humidifier water temperature 20°C.  
2. Dry steam humidifier is defaulted as 775 mm in length and see below table for unit length of film humidifier.

## Wet film humidifier section length

Humidifying efficiency		40%	60%	75%	85%
Mounted behind coil	mm	155	155	310	310
Mounted separately	mm	310	310	465	465

# Horizontal Unit: Fan Outlet Position & Unit Dimension

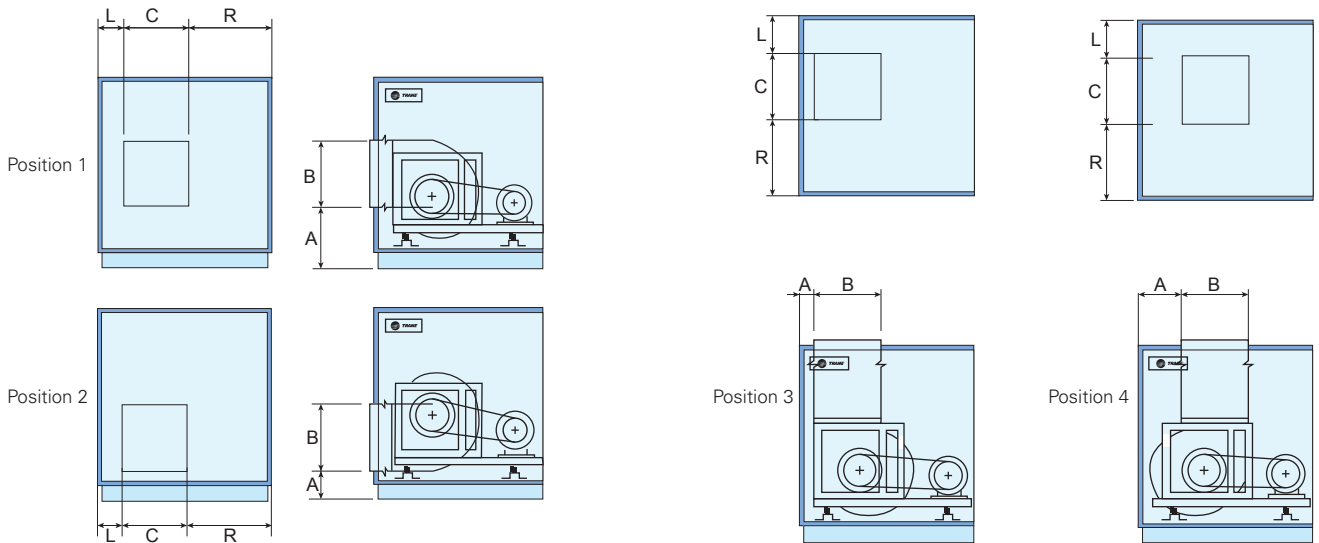

unit: mm

Model Size	Fan outlet position								Motor access door								B	C
	Position 1		Position 2		Position 3		Position 4		Right hand side unit				Left hand side unit					
	A								L		R		L		R			
	25mm	50mm	25mm	50mm	25mm	50mm	25mm	50mm	25mm	50mm	25mm	50mm	25mm	50mm	25mm	50mm		
003-1010	353	378	254	279	94	119	189	214	222	247	221	246	222	247	221	246	246	246
004-1510	366	391	254	279	134	159	258	283	190	215	503	528	504	529	189	214	306	306
006-2010	368	393	254	279	132	157	262	287	234	259	735	760	736	761	233	258	340	340
008-2510	330	355	219	244	133	158	281	306	371	396	870	895	871	896	370	395	378	378
010-2015	421	446	253	278	131	156	299	324	196	221	691	716	692	717	195	220	422	422
012-2515	494	519	274	299	132	157	353	378	229	254	866	891	867	892	228	253	524	524
014-3015	494	519	274	299	132	157	353	378	229	254	1176	1201	1177	1202	228	253	524	524
016-2520	522	547	274	299	133	158	381	406	262	287	771	796	772	797	261	286	586	586
020-3020	544	569	274	299	133	158	403	428	301	326	972	997	973	998	300	325	656	656
025-3025	645	670	344	369	135	160	436	461	311	336	886	911	887	912	310	335	732	732
030-3030	645	670	344	369	135	160	436	461	311	336	886	911	887	912	310	335	732	732
035-3530	687	712	343	368	135	160	478	503	329	354	1092	1117	1093	1118	328	353	818	818
040-4030	735	760	345	370	135	160	526	551	441	466	1192	1217	1193	1218	440	465	916	916
045-4530	735	760	345	370	135	160	526	551	596	621	1347	1372	1348	1373	595	620	916	916
050-5030	798	823	351	376	135	160	582	607	637	662	1508	1533	1509	1534	636	661	1024	1024
060-5035	-	823	-	376	-	160	-	607	-	662	-	1533	-	1534	-	661	1024	1024
065-5535	-	874	-	370	-	160	-	664	-	731	-	1650	-	1651	-	730	1148	1148
070-6035	-	874	-	370	-	160	-	664	-	886	-	1805	-	1806	-	885	1148	1148
080-6535	-	897	-	372	-	162	-	687	-	891	-	1974	-	1975	-	890	1284	1284
085-7035	-	897	-	372	-	162	-	687	-	1046	-	2129	-	2130	-	1045	1284	1284
090-7535	-	897	-	372	-	162	-	687	-	1201	-	2284	-	2285	-	1200	1284	1284
095-8035	-	897	-	372	-	162	-	687	-	1356	-	2439	-	2440	-	1355	1284	1284
100-8040	-	964	-	372	-	162	-	760	-	1355	-	2284	-	2285	-	1354	1440	1440

# Vertical Unit: Fan Outlet Position & Unit Dimension

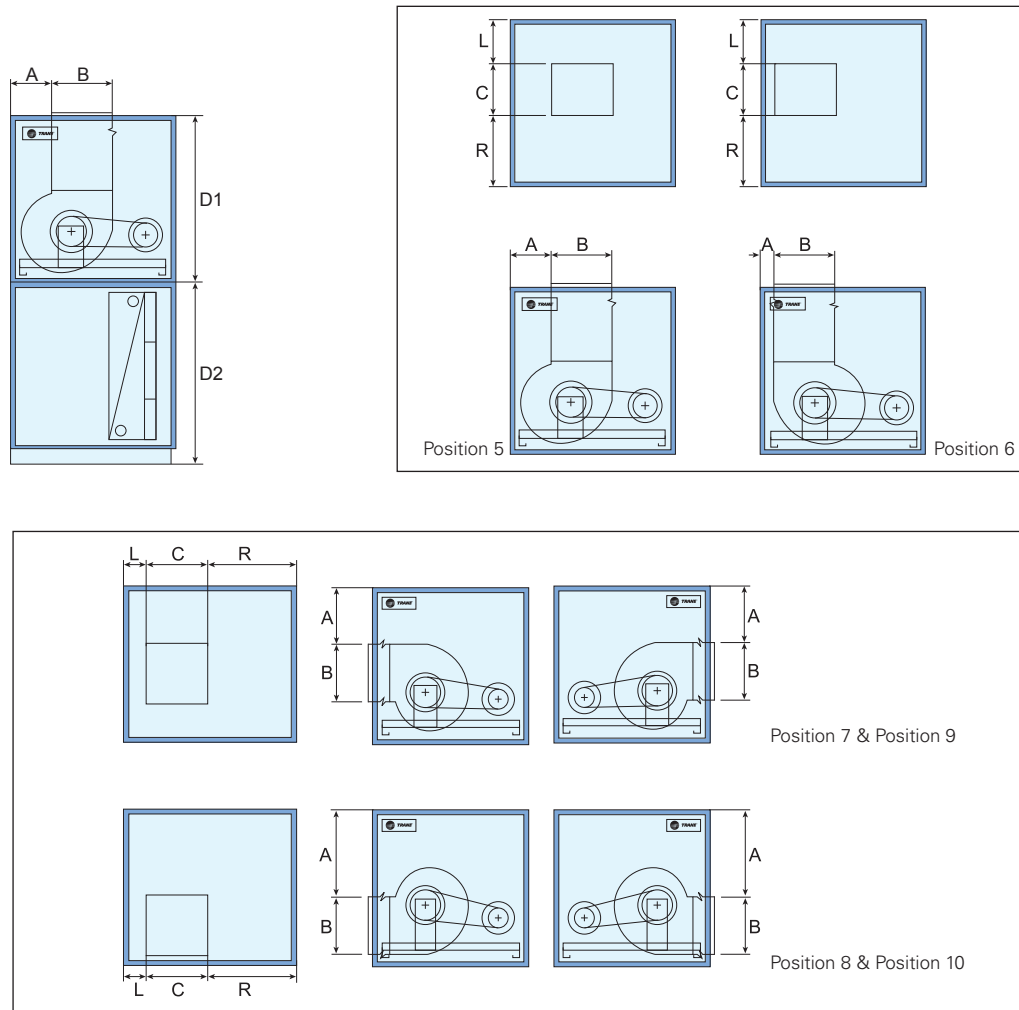

Model Size	Fan outlet position						Motor access door										B	C	D1		D2	
	Position 1		Position 2		Position 3		Position 4		Right hand side unit		Left hand side unit		25mm	50mm	25mm	50mm			25mm	50mm		
	A						L		R		L										R	
	25mm	50mm	25mm	50mm	25mm	50mm	25mm	50mm	25mm	50mm	25mm	50mm									25mm	50mm
003-1010	253	278	154	179	94	119	189	214	222	247	221	246	222	247	221	246	246	246	689	739	789	839
004-1510	266	291	154	179	134	159	258	283	190	215	503	528	504	529	189	214	306	306	689	739	789	839
006-2010	268	293	154	179	132	157	262	287	234	259	735	760	736	761	233	258	340	340	689	739	789	839
008-2510	230	255	119	144	133	158	281	306	371	396	870	895	871	896	370	395	378	378	689	739	789	839
010-2015	321	346	153	178	131	156	299	324	196	221	691	716	692	717	195	220	422	422	999	1049	1099	1149
012-2515	394	419	174	199	132	157	353	378	229	254	866	891	867	892	228	253	524	524	999	1049	1099	1149
014-3015	394	419	174	199	132	157	353	378	229	254	1176	1201	1177	1202	228	253	524	524	999	1049	1099	1149
016-2520	422	447	174	199	133	158	381	406	262	287	771	796	772	797	261	286	586	586	1309	1359	1409	1459
020-3020	444	469	174	199	133	158	403	428	301	326	972	997	973	998	300	325	656	656	1309	1359	1409	1459
025-3025	545	570	244	269	135	160	436	461	311	336	886	911	887	912	310	335	732	732	1619	1669	1719	1769
030-3030	545	570	244	269	135	160	436	461	311	336	886	911	887	912	310	335	732	732	1929	1979	2029	2079
035-3530	-	612	-	268	-	160	-	503	-	354	-	1117	-	1118	-	353	818	818	-	1979	-	2079
040-4030	-	660	-	270	-	160	-	551	-	466	-	1217	-	1218	-	465	916	916	-	1979	-	2079
045-4530	-	660	-	270	-	160	-	551	-	621	-	1372	-	1373	-	620	916	916	-	1979	-	2079
050-5030	-	723	-	276	-	160	-	607	-	662	-	1533	-	1534	-	661	1024	1024	-	1979	-	2079

# Coil Header Position & Dimensions

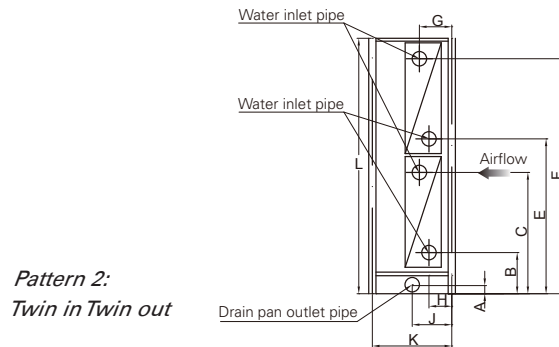
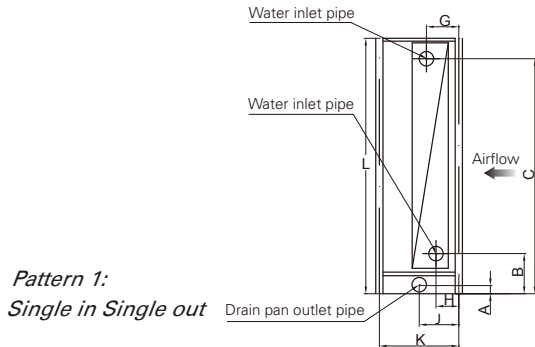

unit: mm

Coil Type	Coil Row	Unit Model	G	J	H		
					WL	LL	DL
Cooling Coil	2	003-120	79	155	145	-	-
	4	003-120	94	155	178	178	217
	6	003-120	94	217	232	232	271
	8	003-120	94	279	287	287	326
	10	003-120	94	310	342	342	381
	12	003-120	94	310	397	397	436
Heating Coil	1	003-120	94	-	144	-	-
	2	003-120	78	-	145	-	-
	4	003-120	94	-	178	-	-

Unit Model	A	B		C		E		F		L		K			D (Connection tube diameter)				
		25mm	50mm	25mm	50mm	25mm	50mm	25mm	50mm	25mm	50mm	1-2 Row	4-6Row	8Row	10-12 Row	1Row	2Row	4-12Row WL/DL	4-12Row LL
003-1010	50	207	232	687	712	-	-	-	-	789	839	310	434	558	620	40	40	40	65
004-1510	50	207	232	687	712	-	-	-	-	789	839	310	434	558	620	40	40	40	65
006-2010	50	207	232	687	712	-	-	-	-	789	839	310	434	558	620	40	40	40	65
008-2510	50	207	232	687	712	-	-	-	-	789	839	310	434	558	620	40	40	40	65
010-2015	50	204	229	989	1014	-	-	-	-	1099	1149	310	434	558	620	40	50	50	65
012-2515	50	204	229	989	1014	-	-	-	-	1099	1149	310	434	558	620	40	50	50	65
014-3015	50	204	229	989	1014	-	-	-	-	1099	1149	310	434	558	620	C 40	50	50	65
016-2520	50	218	243	1294	1319	-	-	-	-	1409	1459	310	434	558	620	A 40	50	65	65
020-3020	50	218	243	1294	1319	-	-	-	-	1409	1459	310	434	558	620	40	50	65	65
025-3025	50	228	253	1590	1615	-	-	-	-	1719	1769	310	434	558	620	40	50	65	65
030-3030	50	204	229	1029	1054	1100	1125	1918	1943	2029	2079	310	434	558	620	40	50	50	65
035-3530	50	204	229	1029	1054	1100	1125	1918	1943	2029	2079	310	434	558	620	40	50	50	65
040-4030	50	204	229	1029	1054	1100	1125	1918	1943	2029	2079	310	434	558	620	40	50	50	65
045-4530	50	204	229	1029	1054	1100	1125	1918	1943	2029	2079	310	434	558	620	40	50	50	65
050-5030	50	204	229	1029	1054	1100	1125	1918	1943	2029	2079	310	434	558	620	40	50	50	65
060-5035	50	-	253	-	1205	-	1320	-	2240	-	2389	310	434	558	620	40	50	65	65
065-5535	50	-	253	-	1205	-	1320	-	2240	-	2389	310	434	558	620	40	50	65	65
070-6035	50	-	253	-	1205	-	1320	-	2240	-	2389	310	434	558	620	40	50	65	65
080-6535	50	-	253	-	1205	-	1320	-	2240	-	2389	310	434	558	620	40	50	65	65
085-7035	50	-	253	-	1205	-	1320	-	2240	-	2389	310	434	558	620	40	50	65	65
090-7535	50	-	253	-	1205	-	1320	-	2240	-	2389	310	434	558	620	40	50	65	65
095-8035	50	-	253	-	1205	-	1320	-	2240	-	2389	310	434	558	620	40	50	65	65
100-8040	50	-	253	-	1364	-	1479	-	2558	-	2699	310	434	558	620	40	50	65	65

Note: 1-1/2" external thread connect pipe, PVC drip pipe as optional. Diameter: inside/outside dimension (50mm/58mm)



Trane - by Trane Technologies (NYSE:TT), a global climate innovator - creates comfortable, energy efficient indoor environments for commercial and residential applications. For more information, please visit [trane.com](https://trane.com) or [tranetechnologies.com](https://tranetechnologies.com).

Trane has a policy of continuous product and product data improvement and reserves the right to change design and specifications without notice. We are committed to using environmentally conscious print practices.